

HYPHERPRO

STEERING DAMPER MOUNTING KIT

for

Yamaha Tenere 700 World Raid Model 2022->

MK-YA07-0001 PART LIST

SD [DS-MV1x-xx]	1	-	-
Damper Clamp [DB078270]	1	-	-
Eye mount [DP-16125]	2	-	-
O-ring	1	-	-
-	-	-	-
-	-	-	-
-	-	-	-
-	-	-	-

ALL IDEAS, DESIGNS ARRANGEMENTS AND PLANS INDICATED OR REPRESENTED BY THIS DRAWING ARE OWNED BY HYPERPRO AND WERE CREATED, EVOLVED AND DEVELOPED FOR USE ON AND IN CONNECTION WITH THE SPECIFIC PROJECT. NONE SUCH IDEAS, DESIGNS, ARRANGEMENTS OR PLANS SHALL BE USED BY OR DISCLOSED TO ANY PERSON, FIRM OR CORPORATION FOR ANY PURPOSE WHATSOEVER WITHOUT THE WRITTEN PERMISSION OF HYPERPRO.

Step 1: remove the original steering damper

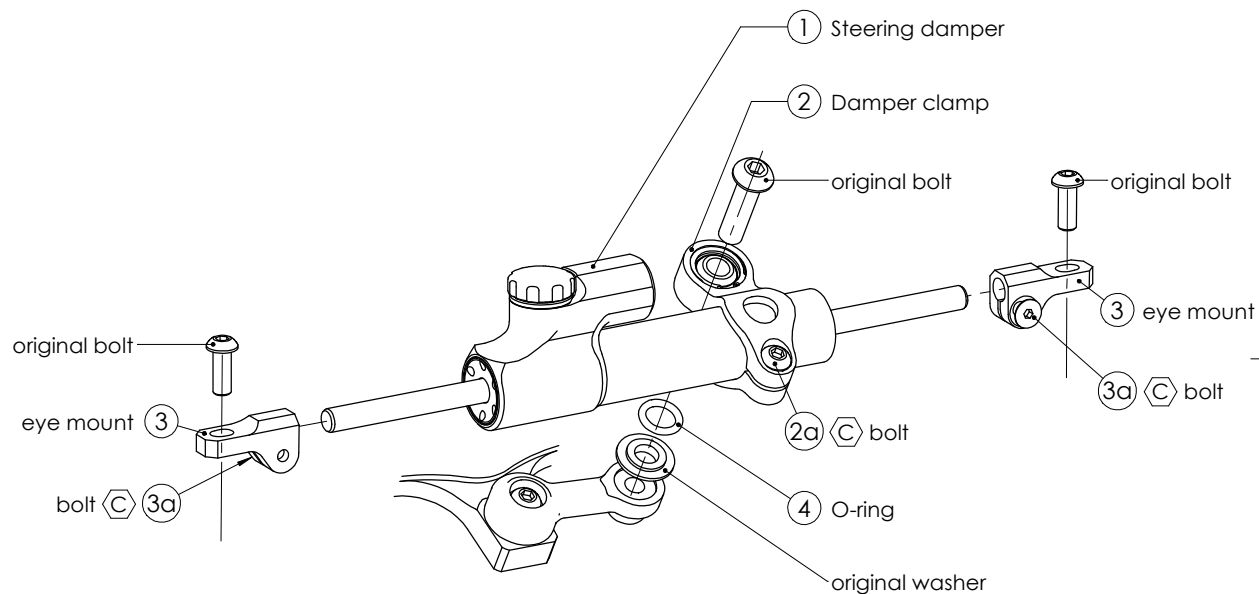

Damping adjustment knob:
 - turn CW to increase damping
 - turn CCW to decrease damping

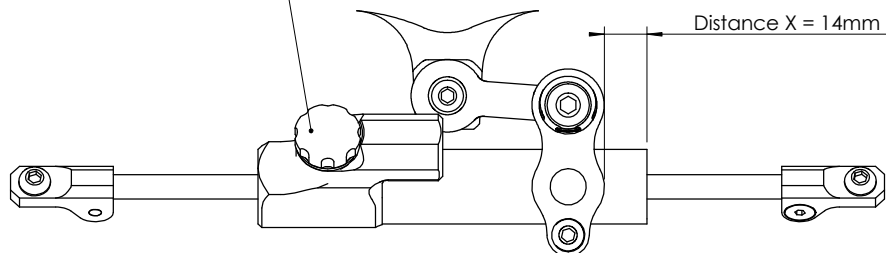

* TORQUES	
A: 5-9Nm / 44-80Lbs.In / 4.0-6.4Lbs.Ft	D: 8Nm / 70Lbs.In / 5.9Lbs.Ft
B: 14-17Nm / 124-150Lbs.In / 10.3-12.5Lbs.Ft	E: 55Nm / 486Lbs.In / 40Lbs.Ft
C: 6Nm / 53Lbs.In / 4.4Lbs.Ft	F: Factory torque (see owners manual)

HYPERPRO

STEERING DAMPER MOUNTING KIT

for

Yamaha Tenere 700 World Raid Model 2022->

MK-YA07-0001 INSTALLATION INSTRUCTIONS

In general:

HYPERPRO can not be held responsible in any way for any form of physical, material, financial or other damage arising from use, assembly or overhaul of HYPERPRO products. HYPERPRO reserves the right to make changes without prior notice.

This product is ONLY TO BE INSTALLED BY A PROFESSIONAL MECHANIC.

This product is only to be used for the motorcycle brand, model and year stated specifically on top of the pages of this manual.

DO NOT attempt to install this product on motorcycles from any different brand, model and/or year than stated on the pages of this manual.

DO NOT use this kit for cars, boats, jet skis, snowmobiles, ATV's, aircraft, hovercrafts or any other vehicle and/or purpose.

HYPERPRO steering dampers are FOR RACE USE ONLY, NOT FOR HIGHWAY USE!

Before installation:

- Please read the entire manual carefully before starting the installation!
- Check if you have all the tools required. Good tools are a must.
- Protect your bike at the most important places in and around the work area (e.g. tank, fairing, frame, etc.), with a blanket, towel or similar.

During installation:

- Check all operations and parts carefully before, during and after performing each step.
- Clean all surfaces that are required for fitting parts together or for applying self adhesives or loctite, thoroughly with contactcleaner or another degreaser, unless otherwise stated.
- Be careful not to damage or scratch any part of your bike.
- ALWAYS work relaxed and concentrated!! It is very easy to damage something or make a mistake.

After installation:

- Check and make sure that there is no contact between any part of the steering damper kit and any part of the motorcycle. The kit should not hit anything. Steering movement should not be limited by the steering damper. If the steering movement is limited, adjust the position of the tube in the clamp until steering movement is normal again. Do not forget to tighten the clamp bolt again!
- ALWAYS check the steering movement and feeling before each ride !
- FIRST RIDES: Start with the damper turned fully open (turn adjuster knob fully counter clockwise). Start adjusting in between rides with steps of MAX. 2 CLICKS (0.25 TURN) EACH TIME, until the damper is working satisfactory for your riding style.
- NEVER USE MAXIMUM SETTING, ALWAYS OPEN AT LEAST 2 CLICKS (0.25 TURN).
- WARNING ! DAMPER HAS AN ACTIVE / SPEEDSENSITIVE DAMPING SYSTEM;
 - Steering with NORMAL MOVEMENT should be FREE !!
 - Steering with FAST MOVEMENT should be CONTROLLED BY DAMPER !!
- HYPERPRO uses a special seal to reduce friction. The seal uses an oil film to work properly. It is normal that some oil can appear on the pistonrod.
- Damper works with oil: DAMPING CAN BE HARDER AT LOWER TEMPERATURES!

Step 1: remove the original steering damper

Remove the M8 bolt and the 2 M6 bolts that mount the original steering damper. Be careful not to lose the original bolts and washer as they have to be used again.

Step 2: assemble and install the steering damper

Assemble the bracket using:

- Fork bracket (4)
- Washer M6 \varnothing 12 (5)
- 1x O-Ring (6)
- Damper Clamp Type 1 (7)
- Bolt M6x25 Low head (8)
- Lock nut M6 (9)

Put the assembly together as shown on page 1:

Shove the damper (1) through the clamp (2) until the distance "X" stated on page 1 is reached, then tighten the clamp bolt (2a) with a torque of approx. 6Nm/53Lbs.In/4.4Lbs.

Place the eye mounts (3) on the ends of the piston rod and mount them to the bike using the original M6 bolts, tighten them and the clamp bolts (3a) to a torque of approx. 6Nm/53Lbs.In/4.4Lbs. Mount the clamp (2) to the link using the original M8 bolt and the O-ring (4) and original washer underneath. Tighten the M8 bolt to a torque of approx. 14-17Nm/124-150Lbs.In/10.3-12.5Lbs.Ft.

Check if the damper is level horizontally and aligned to the bike. Check if the damper does not touch anything (e.g. handlebar risers, tank) when steering from left to right. Check if the bike can make it's full steering angle from left to right. Adjust the position of the damper body if necessary, do not forget to re-tighten the clamp bolts afterwards.